



Champagne... The best sandpaper on the planet.

Champagne is sandpaper technology at its best. It cuts faster, runs cooler, resists loading better and lasts far longer than any conventional sandpaper.

FEATURES

- Premium heat-treated grain
- Premium B-weight latex paper backing
- FEPA P-graded grain
- Redesigned bond system
- Waterbased stearate No-Fil
- No pigment in No-Fil or bond

BENEFITS

- 30% - 50% faster cut rate
- Extended life
- Improved performance
- More flexible
- Easier disc removal
- Achieves a more consistent, uniform scratch pattern
- Optimizes grain adhesion
- Extends cut life
- Improves load resistance
- Extends cut life
- Eliminates the risk of color transfer
- Creates a much stronger bond

PSA Disc Rolls



Premium quality PSA (pressure sensitive adhesive) discs in convenient roll form are ideal for use with Norton Disc Roll Dispensers on page 30. Simply tear off and apply self-adhering disc to Stick and Sand Back-up Pad (see page 31). Packed in handy corrugated boxes for ease of use, and individually wrapped in polybags.

For dust-free sanding, pre-punched PSA vacuum assist discs are available in 5", 6" and 8" sizes.



SIZE	3-1/2" BLANK	5" BLANK	6" BLANK	8" BLANK	5" VAC	6" VAC	PACKAGE	PKG/CASE
------	--------------	----------	----------	----------	--------	--------	---------	----------



GRIT	662611-	662611-	662611-	662611-	662611-	662611-		
P800B	-	31451	31468	-	31485*	31502*	100	6
P600B	-	31452	31469	-	31486	31503	100	6
P500B	-	31453	31470	-	31487	31504*	100	6
P400B	-	31454	31471	-	31488	31505	100	6
P360B	-	41199*	41198	-	41196*	41197*	100	6
P320B	-	31456	31473	-	31490	31507	100	6
P280B	-	31457	31474	-	31491*	31508	100	6
P240B	-	31458	31475	-	31492	31509	100	6
P220B	-	31459	31476	-	31493	31510	100	6
P180B	-	31460	31477	-	31494	31511	100	6
P150B	-	31461	31478	-	31495	31512	100	6
P120B	-	31462	31479	-	31496	31513	100	6
P100B	-	31463	31480	-	31497	31514	100	6
P80B	-	31464	31481	-	31498	31515	100	6
P400B	36368	-	-	31608*	-	-	100	4
P320B	36369	-	-	31609	-	-	100	4
P280B	36370*	-	-	31610*	-	-	100	4
P240B	36371	-	-	31611*	-	-	100	4
P220B	36372	-	-	31612	-	-	100	4
P180B	36373	-	-	31613	-	-	100	4
P150B	36374	-	-	31614	-	-	100	4
P120B	36375	-	-	31615	-	-	100	4
P100B	-	-	-	31616*	-	-	100	4
P80B	36376	-	-	31617	-	-	100	4

* NON-STOCK

PSA Discs



Finer grits can be used dry on base coat / clear coat systems to save time and money and increase worktime productivity.



SIZE	5" PSA	6" PSA	8" VAC	PACKAGE	PKG/CASE
GRIT	662611-	662611-	662611-		
P1500B	31448*	31465	-	100	4
P1200B	31449	31466	-	100	4
P1000B	31450	31467	-	100	4
P320B	-	-	25118	100	4
P220B	-	-	25710*	100	4
P180B	-	-	24483	100	4

* NON-STOCK

Speed-Grip Discs



No system anywhere holds better or fastens more easily than Speed-Grip. The quick-change hook and loop fastening system locks and unlocks each and every time. Provides cooler cutting action and a finer finish.

For dust-free sanding, Speed-Grip, the Norton quick-change fastening system, is available in pre-punched 5" and 6" vacuum assist discs.

Back-up pads are on page 31.



SIZE	3" BLANK	5" BLANK	6" BLANK	8" BLANK	5" VAC	6" VAC	PACKAGE	PKG/CASE
GRIT	662611-	662611-	662611-	662611-	662611-	662611-		
P1500B	-	31533	31550	-	31567*	31584	100	4
P1200B	-	31534	31551	-	31568*	31585	100	4
P1000B	-	31535	31552	-	31569*	31586	100	4
P800B	-	31536	31553	-	31570*	31587	100	4
P600B	-	31537	31554	29173*	31571	31588	100	4
P500B	-	31538	31555	-	31572*	31589*	100	4
P400B	-	31539	31556	24595*	31573	31590	100	4
P360B	-	41201	41200	-	41203*	41202*	100	4
P320B	-	31541	31558	31659*	31575	31592	100	4
P280B	-	31542	31559	-	31576	31593	100	4
P240B	-	31543	31560	29294*	31577	31594	100	4
P220B	-	31544	31561	31660*	31578	31595	100	4
P180B	-	31545	31562	31661	31579	31596	100	4
P150B	-	31546	31563	-	31580	31597	100	4
P120B	-	31547	31564	31662	31581	31598	100	4
P100B	-	31548	31565	31663	31582	31599	100	4
P80B	-	31549	31566	31664*	31583	31600	100	4
P1500B	47434	-	-	-	-	-	50	4
P1000B	35900	-	-	-	-	-	50	4
P800B	31519	-	-	-	-	-	50	4
P600B	36996	-	-	-	-	-	50	4
P500B	31521	-	-	-	-	-	50	4
P400B	36995	-	-	-	-	-	50	4
P320B	31524	-	-	-	-	-	50	4
P240B	31526	-	-	-	-	-	50	4
P220B	31527	-	-	-	-	-	50	4
P180B	31528	-	-	-	-	-	50	4
P80B	31532	-	-	-	-	-	50	4

* NON-STOCK

Discs



Champagne discs are available in a full line-up of grits that offer you superior cutting performance and longer life. For use with Norton Disc Adhesive on page 41, and Glue-On back-up pads on page 33.



SIZE	5" BLANK	6" BLANK	PACKAGE	PKG/CASE
GRIT	662611-	662611-		
P800B	25612*	25613*	100	10
P320B	25103*	25111	100	5
P240B	25104*	25112	100	5
P220B	25105*	25113	100	5
P180B	25106*	25114	100	5
P150B	25107*	25115	100	5
P120B	25108*	-	100	5
P100B	25109*	25116*	100	10
P80B	25110*	25117	100	5

* NON-STOCK (ALL NON-STOCKS ARE 10 PKG/CASE)

Body File Sheets



These body file sheets are a popular choice for dry sanding paint, primer, primer surfacer, and between color coats; also for deburring, removing sand scratches, shaping and finishing plastic filler, and feather-edging repaired areas. Special No-Fil coating prevents premature loading.

Champagne body file sheets come in three different types: Clip-On, PSA and Speed-Grip.



Clip-On

SIZE	2-3/4" X 17-1/2"	PACKAGE	PKG/CASE
GRIT	662611-		
P220B	31647	50	10
P180B	31648	50	10
P150B	31649	50	10
P120B	31650	50	10
P100B	31651	50	10
P80B	31652	50	10

PSA

SIZE	2-3/4" X 16-1/2"	PACKAGE	PKG/CASE
GRIT	662611-		
P220B	31635*	50	10
P180B	31636	50	10
P150B	31637*	50	10
P120B	31638*	50	10
P100B	31639	50	10
P80B	31640	50	10

Speed-Grip

SIZE	2-3/4" X 16-1/2"	2-3/4" X 16" VAC	PACKAGE	PKG/CASE
GRIT	662611-	662611-		
P220B	31641	31653*	50	10
P180B	31642	31654	50	10
P150B	31643	31655*	50	10
P120B	31644	31656	50	10
P100B	31645	31657	50	10
P80B	31646	31658	50	10



* NON-STOCK

9" x 11" Sheets



Popular choice for dry sanding old paint, primer, primer surfacer, and between color coats; also for deburring, removing sand scratches, shaping and finishing plastic filler, and feather-edging repaired areas. Special No-Fil coating prevents premature loading. Can be cut into thirds to fit neatly on jitterbug sanders.





SIZE	9" X 11"	PACKAGE	PKG/CASE
			
GRIT	662611-		
P1500B	31618	100	5
P1200B	31619	100	5
P1000B	31620	100	5
P800B	31621	100	5
P600B	31622	100	5
P500B	31623	100	5
P400B	31624	100	5
P320B	31626	100	5
P280B	31627	100	5
P240B	31628	100	5
P220B	31629	100	5
P180B	31630	100	5
P150B	31631	100	5
P120B	31632	100	5
P100B	31633	100	5
P80B	31634	50	5

PSA Sheet Rolls



Stick and Sand Sheet Rolls are PSA backed, so you can peel them off easily and stick them on at any length, quickly. Use on hand sanding blocks, file boards, file shoes or file boards. Fits sheet-roll dispenser #42773 on page 30.

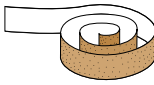
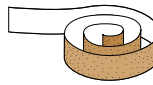
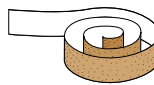

SIZE	2-3/4" X 25 YDS	2-3/4" X 30 YDS	2-3/4" X 45 YDS	PACKAGE	PKG/CASE
					
GRIT	662611-				
P600B	-	-	31679*	1	5
P400B	-	-	31681	1	5
P320B	-	-	31683	1	5
P280B	-	-	31684*	1	5
P240B	-	-	31685	1	5
P220B	-	-	31686	1	5
P180B	-	-	31687	1	5
P150B	-	-	31688	1	5
P120B	-	31689	-	1	5
P100B	-	31690	-	1	5
P80B	31691	-	-	1	5

* NON-STOCK



Blue Magnum... The roughest, toughest sandpaper ever made.

Blue Magnum, with super strong phenolic resin as a bonding agent, "is simply the best in the world!" Couple this with flexible latex backing — in an indestructible E-weight — and the end result is one of the toughest, longest lasting, high performance coarse grit sandpapers ever made. "Absolutely, positively."

FEATURES

- High strength blue latex paper backing
- Latest NorZon grain design
- New coating technique
- Redesigned bond system

BENEFITS

- Improves performance and flexibility
- Reduces curling and edge chipping
- Self-sharpening
- Improves cut rate
- Extends product life
- Improves cut rate
- More consistent, uniform scratch pattern
- Optimizes grain adhesion
- Extends product life

PSA Discs



Norton Blue PSA Discs are the workhorse of the industry. Save time and money and increase productivity. PSA backed for convenient application.

SIZE	5" PSA	6" PSA	8" PSA	5" VAC	6" VAC	8" VAC	PKG	PKG/CASE
GRIT	662611-	662611-	662611-	662611-	662611-	662611-		
80E	25244	23573	—	25508*	23579*	—	50	4
40E	25307	23574	—	24919	23580	—	50	4
36E	25436	23575	—	24920	23581*	—	50	4
80E	—	—	23576	—	—	23582	25	4
40E	—	—	23577	—	—	23583	25	4
36E	—	—	23578	—	—	23584	25	4

* NON-STOCK

Discs



Another industry workhorse, these tough, long-lasting, high performance Norton Blue Discs increase productivity to save you time and money. Hard, self-sharpening grain makes it ideal for use on both metal and plastic. For use with Norton Disc Adhesive on page 41, and Glue-On back-up pads on page 33.

SIZE	6" BLANK	8" BLANK	PACKAGE	PKG/CASE
GRIT	662611-	662611-		
80E	23602	—	50	4
40E	23603	—	50	4
36E	23604	—	50	4
80E	—	23605	25	4
40E	—	23606	25	4
36E	—	23607	25	4



Speed-Grip Discs



Hook and loop fastening system allows for cool running characteristics that result in reduced loading, less frequent change-overs, and greater overall efficiency in productivity. Ideal for sanding body filler.

SIZE	5" BLANK	6" BLANK	8" BLANK	8" VAC	8" VAC	PACKAGE	PKG/CASE
GRIT	662611-	662611-	662611-	662611-	662611-		
80E	25444	23588	23591	23596	23599*	25	4
40E	25684	23589	23592	23597*	23600*	25	4
36E	-	23590	23593	23598	23601*	25	4

* NON-STOCK



Body File Sheets

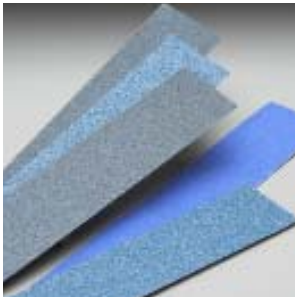

Norton Blue Body File Sheets come in three different types; Clip-On, PSA and Speed-Grip. Pick the one that's right for your job. Tough, high performance body files will make short work of your sanding needs. Ideal for sanding body filler.

Clip-On

SIZE	2-3/4" X 17-1/2"	PACKAGE	PKG/CASE
GRIT	662611-		
180E	26511	50	5
100E	26512	50	5
80E	23620	50	5
40E	23621	50	5
36E	23622	50	5

PSA

SIZE	2-3/4" X 16-1/2" PSA	2-3/4" X 16" PSA VAC	PACKAGE	PKG/CASE
GRIT	662611-	662611-		
100E	25595	-	50	10
80E	23608	23611	50	5
40E	23609	23612*	50	5
36E	23610	23613*	50	5

Speed-Grip

SIZE	2-3/4" X 16-1/2"	2-3/4" X 16" VAC	PACKAGE	PKG/CASE
GRIT	662611-	662611-		
80E	23614	23617	25	5
40E	23615	23618	25	5
36E	23616	23619*	25	5

* NON-STOCK



NORZON BLUE STRIPPER



NorZon... A legendary workhorse.

Heavy duty fibre and cloth grinding discs are preferred by body shops for tough jobs like paint removal, cutting down plastic filler or prepping bare metal. Made with superior zirconia alumina abrasive, the NorZon family of products outperforms and outlasts the competition. The unique grain composition promotes a quick initial cut and actually self-sharpens with continued use.

FEATURES

- Superior zirconia alumina grain
- Super hard phenolic resin bond system

BENEFITS



- Promotes quick initial cut
- Actually self-sharpens with continued use
- Optimizes grain adhesion
- Extends product life

NorKut Grinding Discs



NorKut grinding discs are made with rugged NorZon grain so it cuts fast and lasts long. Resin bonded to a unique backing which resists cracking and breaking, these discs can be cut down to any size up to the 1" core. Use the cores to grind "pinch" welds and other hard to reach areas. Two quick change mandrels allow NorKut to be used on most popular tools. 7/16"-20 thread is for use with hand held pneumatic grinders while the 1/4" mandrel is for use on automotive drills.



SIZE	3"	7/16"-20	1/4" HEX	PACKAGE	PKG/CASE
					
GRIT	636425-	636425-	636425-		
50	03658	—	—	20	4
36	03657	—	—	20	4
24	03656	—	—	20	4
Mandrel	—	03659	—	5	10
Mandrel	—	—	03660	5	10

NORZON BLUE STRIPPER

NorZon Blue Stripper Speed-Lok and Speed-Lok TR Grinding Discs

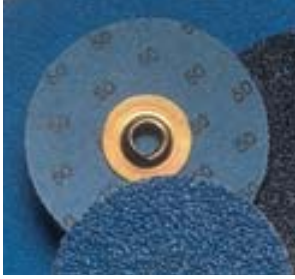

Double laminated cloth discs get into hard-to-reach areas for the toughest jobs. Norton's Speed-Lok and Speed-Lok TR systems permit instant disc mounting and removal. When you are ready to change the disc, simply twist it off.



Speed-Lok and Speed-Lok TR Grinding Discs

SIZE	2"	2" TR	3"	3" TR	PACKAGE	PKG/CASE
GRIT	662611-	662611-	662611-	662611-		
80	38633	21049	38660	21054	25	1
60	38634	21048	38661	21053	25	1
50	38635	38670	38662	38673	25	1
36	38637	38671	38664	38674	25	1
24	38638	38672	38665	38675	25	1

Speed-Lok and Speed-Lok TR Back-up Pads

SIZE	2"	3"	PACKAGE	PKG/CASE
636425-	636425-			
Speed-Lok Back-up Pad	43210	43225	1	1
662610-	662610-			
Speed-Lok TR Back-up Pad	55103	55105	1	1



NorZon Blue Stripper Grinding Discs

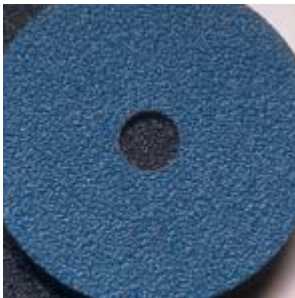

Superior zirconia alumina abrasive makes Blue Stripper fibre discs outperform and outlast conventional discs. A quick initial cut and a self-sharpening action continuously expose keen, new cutting points. Its cooler-running characteristic results in reduced loading, less frequent disc change-overs, and greater efficiency and productivity.



Grinding Discs

SIZE	5"	7"	9-1/8"	PACKAGE	PKG/CASE
GRIT	662611-	662611-	662611-		
80	38600	38590	-	25	1
60	38601	38591	-	25	1
50	38561	38592	38582	25	1
36	38562	38593	38583	25	1
24	38563	38594	38584	25	1

Back-up Pads for Grinding Discs

SIZE	5"	7"	9-1/8"	PACKAGE	PKG/CASE
636425-	636425-	636425-			
Back-up Pads	43421	43422	43423	1	1



Black Ice... For the ultimate finish.

Norton, the world's largest manufacturer of abrasives, has developed an entire line of durable and flexible waterproof products that increase productivity and profitability—while achieving the ultimate finish.

FEATURES

- Premium abrasive grain
- Improved flexible backing
- FEPA and JIS grading



BENEFITS

- Fast initial cut, long life
- Grain selection engineered for automotive applications
- Resists cracking and tearing
- Resists wrinkles and curling
- Consistent finish
- No wild scratches
- Buffs out faster

Black Ice Waterproof Sanding Paper Sheets



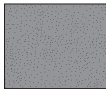

For the ultimate finish, premium grain on a superior paper backing allows for improved cut rate and a uniform finish. Both the bond and the backing are extremely flexible for easy folding and tearing, wet or dry. Engineered specifically for the automotive aftermarket, Black Ice delivers unsurpassed results in waterproof and color sanding.

SIZE	5-1/2" X 9"	9" X 11"	PACKAGE	PKG/CASE
				
GRIT	662611-	662611-		
2500A	39369	39377	50	5
2000A	39370	39378	50	5
1500A	39371	39379	50	5
1200A	39372	39380	50	5
1000A	39373	39381	50	5
P800B	39374	39382	50	5
P600B	39375	39383	50	5
P500B	—	39384	50	5
P400B	—	39385	50	5
P360B	—	39346	50	5
P320B	—	39386	50	5
P280B	—	39387	50	5
P240B	—	39388	50	5
P220B	—	39389	50	5
Bucket	04413		1	5

Waterproof Sanding Paper Sheets

The best for wet sanding the final feather-edge. Can be used wet or dry for old paint finishes, primer and primer surfacer. Washes clean. Resists loading, tearing, and curling.

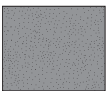
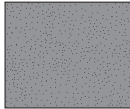

SIZE	5-1/2" X 9"	9" X 11"	PACKAGE	PKG/CASE
				
GRIT	662611-	662611-		
P2000B	28332	26053	50	5
P1500B	28333	26054	50	5
P1200B	28334	26055	50	5
P1000B	28335	26056	50	5
P800B	28336	39347	50	5
P600B	28337	26057	50	5
P500B	—	26058	50	5
P400B	—	26059	50	5
P320B	—	26060	50	5
P280B	—	26061	50	5
P240B	—	26062	50	5
P220B	—	26063	50	5



**Gold...
the hardest working
sandpaper for the money.**

Body shop pros can cut faster on the job and produce a finer, more consistent finish... with the best abrasives for the money that Norton knows how to make!

FEATURES	BENEFITS
<ul style="list-style-type: none"> ■ "P" graded aluminum oxide grain ■ Strong paper backing ■ Exclusive No-Fil formula 	<ul style="list-style-type: none"> ■ Produces a quick, cool cut ■ Produces a finer, more consistent scratch pattern ■ Resists tearing ■ Improves sanding ■ Cuts faster ■ Resists loading ■ Increases productivity

PSA Discs



Ideal for rough feather-edging, stripping old paint and dry sanding plastic filler and putty. Sharp, hard aluminum oxide abrasive on a tough paper backing for aggressive sanding and long life. No-Fil and OpenKote prevent clogging and loading. Disc Rolls are ideal for use with Norton Disc Roll Dispensers on page 30.



SIZE	5" PSA DISC ROLL	6" PSA DISC ROLL	5" VAC DISC ROLL	6" VAC DISC ROLL	6" PSA SPLIT LINER	PACKAGE	PKG/CASE
GRIT	662611-	662611-	662611-	662611-	662611-		
P400C	49821	49833	30257	30267*	48834	100	4
P320C	49822	49834	30258	30268	48835	100	4
P280C	49823	49835	-	-	-	100	4
P240C	49824	49836	30259	-	48837	100	4
P220C	49825	49837	30260*	30271	48838	100	4
P180C	49826	49838	30261	30272	48839	100	4
P150C	49827	49839	30262	30273	48840	100	4
P120C	49828	49840	30263	30274	48841	100	4
P100C	49829	49841	30264	30275	48842	100	4
P80C	49830	49842	30265	30276	48843	100	4
P60C	49831	49847	30266	-	-	100	4

* NON-STOCK

PSA Discs

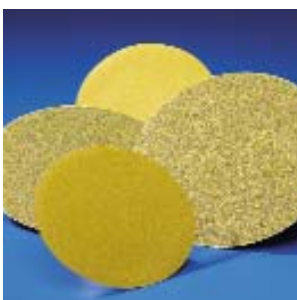

PSA discs stick tight and hold securely to prevent wrinkling and tearing. Fast, easy to use and remove. With transparent liner to protect the adhesive from dirt and contaminants. Use with Norton Stick and Sand Disc Pads on page 31.



SIZE	6" PSA	8" PSA	PACKAGE	PKG/CASE
GRIT	662611-	662611-		
P80E	-	30826	50	4
P40E	-	30827	50	4
P36E	-	30828	50	4
P80E	30832	-	100	4
P40E	30833	-	100	4
P36E	30834	-	100	4

Speed-Grip Discs

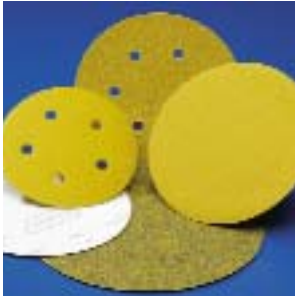

No system anywhere holds better or fastens more easily than Speed-Grip. The quick-change hook and loop fastening system locks and unlocks each and every time. Provides cooler cutting action and a finer finish.

For dust-free sanding, Speed-Grip, the Norton quick-change fastening system, is available in pre-punched 5" and 6" vacuum assist discs.



Discs

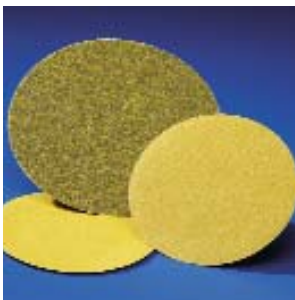

No-Fil Paper Openkote is ideal for rough feather-edging, stripping old paint and dry sanding plastic filler and putty. Sharp, hard aluminum oxide abrasive on a tough paper backing for aggressive sanding and long life. No-Fil and Openkote prevent clogging and loading.



SIZE	5" BLANK	6" BLANK	8" BLANK	PACKAGE	PKG/CASE
GRIT	662611-	662611-	662611-		
P400C	49899	49908	—	100	4
P320C	49900	49909	—	100	4
P280C	49901*	49910	—	100	4
P240C	21613*	17588*	—	100	4
P220C	49902	49911	—	100	4
P180C	49903	49912	—	100	4
P150C	49904	49913	—	100	4
P120C	49905	49914	—	100	4
P100C	49906	49915	—	100	4
P80C	49907	49916	—	100	4
P60C	30224	30225	—	100	4

P40E	—	31231*	31227*	25	10
P36E	—	31232*	31228*	25	10

SIZE	5" X 5 HOLE	5" X 8 HOLE	6" X 6 HOLE	PACKAGE	PKG/CASE
GRIT	662611-	662611-	662611-		
P400C	30226	—	30246*	50	4
P320C	30227	30238	30247	50	4
P220C	30230	30239	30250	50	4
P180C	30231	30240	30251*	50	4
P150C	30232	30241	30252*	50	4
P120C	30233	30242	30253	50	4
P100C	30234	30243	30254	50	4
P80C	30235	30244	30255	50	4
P60C	30236	30245	30256*	50	4

* NON-STOCK

SIZE	5" BLANK	6" BLANK	8" BLANK	PACKAGE	PKG/CASE
GRIT	662611-	662611-	662611-		
P400C	49918*	49932*	—	100	5
P320C	49919*	49933	—	100	5
P280C	49920*	49934*	—	100	5
P220C	49921*	49935	—	100	5
P180C	49922	49936	49941	100	5
P150C	49923	49937*	—	100	5
P120C	49924	49938	—	100	5
P100C	49925	49939	—	100	5
P80C	49926	49940	49942	100	5
P60C	49927	—	—	100	5

P80E	—	—	30829*	100	4
P40E	—	30803*	30830	100	4
P36E	—	—	30831	100	4

* NON-STOCK

Body File Sheets



No-Fil C-weight paper is popular for removing burrs and scratches, cutting down fillers, putty and old paint, and for fast, non-loading sanding of primers. No-Fil keeps the grain free to cut longer. Heavy-duty E-weight backing resists tearing and improves sanding. Available in convenient Clip-On, PSA and Speed-Grip fastenings.



Clip-On and PSA

SIZE	2-3/4" X 17-1/2"	2-3/4" X 16-1/2" PSA	PACKAGE	PKG/CASE
GRIT	662611-	662611-		
P220C	01127	—	50	10
P180C	01128	—	50	10
P150C	01129	—	50	10
P80C	01120	—	50	10
P60C	01121*	—	50	10
P80E	30835	30838	50	10
P40E	30836	30839	50	10
P36E	30837	30840	50	10

Speed-Grip

SIZE	2-3/4" X 16-1/2"	PACKAGE	PKG/CASE
GRIT	662611-		
P80C	12008*	50	5
P40E	31237*	50	5
P36E	31238*	50	5

* NON-STOCK

Sheets



Available in both flexible A-weight and sturdy C-weight design, No-Fil Paper Openkote makes an excellent general duty sheet for dry sanding applications on metal, plastic, or fiberglass automotive surfaces. Tough aluminum oxide grain is specially spaced to resist loading for long cutting action. Effective for feather-edging, removing burrs and sanding plastic filler, and removing old paint.



SIZE	3-2/3" X 9"	9" X 11"	PACKAGE	PKG/CASE
GRIT	662611-	662611-		
P400A	—	84098	100	5
P320A	—	84100	100	5
P280A	—	84101	100	5
P240A	—	84102	100	5
P220A	—	84103	100	5
P180A	—	84104	100	5
P150A	—	84108	100	5
P120A	—	84105	100	5
P100A	—	84106	100	5
P80A	—	84107	50	5
P320C	01122	—	100	10
P220C	01123	—	100	10
P180C	01124	—	100	10
P150C	01125	—	100	10
P120C	01126*	—	200	10
P80C	01119	—	100	10

* NON-STOCK



Bear-Tex.... Tough, flexible and rust-proof

Bear-Tex products resist loading, and are extremely flexible to help get into the hard-to-reach places.

FEATURES

- Improved weave design
- Improved tensile strength
- Improved flexibility

BENEFITS

- Strengthens the pad
- Allows for a more uniform scratch pattern
- Rinses easily for reuse
- Resists shredding and tearing
- Good for hard to reach places

Bear-Tex Scuff Pads



Bear-Tex automotive scuff pads effectively remove paint overspray, dirt, corrosion and rust. Tough synthetic fiber pads won't rust, shred, or stain, and can be rinsed and reused repeatedly. Use on old paint, primer surfacer, metal, plastic, body filler, or fiberglass. Strong, yet flexible, for getting into tight places.



White, Light Duty non-abrasive pads won't scratch the surface. They can be used for light primer rub-down, general clean up, and paint overspray.

SIZE	6" X 9"	PACKAGE	PKG/CASE
------	---------	---------	----------



DESCRIPTION	COLOR	662610-		
Light Duty	White	58001	20	3
Final Prep	Gray	58002	20	3
Scuff & Clean	Maroon	58000	20	3

Gray, Final Prep pads are perfect for the final preparation of primer-surfacers. And no other pad can blend a finish better or scuff between primer and color coats. Ideal for today's paint systems.

Maroon, Heavy-Duty hand pads are ideal for prepping replacement parts. Strong, yet flexible enough to get into the hardest to reach places. Redesigned for automotive applications for a fast, aggressive cut.



Blendease



Blendease is specially formulated to be used with a gray Bear-Tex Scuff Pad #58002 to prep and blend panels prior to painting.



SIZE	1 LITRE	PACKAGE	PKG/CASE
------	---------	---------	----------

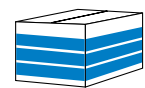

DESCRIPTION	636425-			
Blendease (1 litre)	04710	1		4

Bear-TEX Rapid Strip Discs

Bear-TEX Rapid Strip Discs are constructed with thick, strong synthetic fibers and extra-coarse silicon carbide abrasive. The open web construction of the disc provides fast cutting action with very little loading. Safer than wire bristle tools, THE BEAST aggressively removes rust and paint from drip moldings, pinch welds, door jambs, seams and other difficult to reach areas. The robust TR+ attachment system allows for rugged cleaning in tight areas. TR+ can be used on all competitive back-up pads utilizing a similar system.





Excellent for removal of rust, undercoating, seam-sealers and stone guards, these discs can get into hard-to-reach areas like wheel wells and under carriage. Ideal for trunk beds and door jambs. Use to remove oxidation from tire rims and to remove rust from brake assemblies.

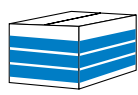

THE BEAST - Bear-TEX Rapid Strip Disc TR+ Disc

SIZE	BACK-UP PAD	4" TR+	RPM	PKG	PKG/CASE
					
COLOR	636425-	662610-			
Black		21780	8000	5	1
Back-up Pad	55106			1	1

THE BEAST - Bear-TEX Rapid Strip Disc with Mandrel

SIZE	MANDREL	4" X 1/4" HOLE	RPM	PKG	PKG/CASE
					
COLOR	662610-	662610-			
Black		09324	6000	5	4
Mandrel	09502			1	1
3-1/16 x 1/4" Shank					

Bear-TEX Speed-Lok TR Rapid Strip Disc

SIZE	2" TR	3" TR	RPM	PKG	PKG/CASE
					
COLOR	662610-	662610-			
Black	11782	-	15000	10	1
Black	-	11781	12000	10	1
DESCRIPTION	662610-	662610-			
Back-up Pad	55103	55105		10	1



Bear-TEX Surface Blending Discs



- Blue = Fine (320)
- Maroon = Medium (120)
- Brown = Coarse (80)



Bear-TEX Surface Blending Discs deliver superior, consistent finishes whenever you need to clean, deburr, blend or finish. Bear-TEX surface blending discs provide a higher rate of cut for increased productivity and much longer life. Ideal for removing rust and oxides, blending out disc marks, and removing coatings and gasket residues from automotive surfaces. Thick, reinforced non-woven backing is impregnated with tough aluminum oxide abrasive.

Product color coding (by grit) makes work fast and easy.

See pages 32 and 33 for back-up pads.

Disc Attachment Systems



Speed-Grip Surface Blending discs feature a hook and loop fastening system.

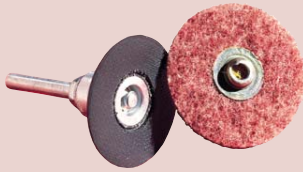

Speed-Lok surface blending discs are compatible with the Norton Speed-Lok and Standard Abrasives Quick Change attachment systems.



Speed-Lok TR surface blending discs are compatible with the Norton Speed-Lok TR and 3M Roloc™ attachment systems.

Bear-TEX Brushes



Made with tough, yet flexible nylon filaments heavily embedded with silicon carbide abrasive. Bear-TEX brushes offer significant advantages over wire brushes, steel wool, and other abrasive forms where conformability and longer life are needed. Patented process interlocks abrasive bristles with brush backing for a uniform finish without loading or shedding. Excellent for work on pick-up truck beds. Requires air-cooled back-up pad for operation, found on page 34.

Speed-Grip

SIZE	4"	7"	CASE
GRIT	662610-		
Medium	55019	–	40
Coarse	55018	–	40
Fine	–	55029	25
Medium	–	55028	25
Coarse	–	55027	25

Speed-Lok

SIZE	2" SPEED-LOK	3" SPEED-LOK	CASE
GRIT	662610-		
Medium	09182	–	50
Coarse	09183	–	50
Medium	–	09185	25
Coarse	–	09186	25

Speed-Lok TR

SIZE	2" SPEED-LOK TR	3" SPEED-LOK TR	CASE
GRIT	662610-		
Fine	09189	–	50
Medium	09190	–	50
Coarse	09191	–	50
Fine	–	09192	25
Medium	–	09193	25
Coarse	–	09194	25

SIZE	7" X 1" X 7/8"	CASE
GRIT	662610-	
120	58834	5
80	58830	5



AVOS.... Allows View Of Surface.

AVOS is a revolutionary abrasive system for portable grinders. The unique shape of AVOS discs allows the operator to see the edges of the surface area being ground, while the disc is spinning. Strategically positioned holes complete the view. Being able to see the surface while grinding enables an operator to work faster and more accurately, and produce a superior finish.

FEATURES

- Unique, advanced see-thru design
- 5 degree back-up pad
- Speed-Lok design

BENEFITS

- Improves vision
- Improves cut rate
- Increases air flow allowing for up to 25% cooler cutting
- Improves cut rate
- Provides more consistent, uniform scratch pattern
- Extends product life
- Increases air flow
- Quick change
- Less downtime

Pistol Grip Adapter and Speed-Lok Mounting System



SIZE	RPM	PACKAGE	PKG/CASE
5"	20000	1	5
5" Trial Kit includes: - One 7/16" x 20 back-up pad - One pistol grip adapter - One 36 grit SG Fibre disc - One coarse Bear-Tex disc			



An adapter is included with each back-up pad to allow AVOS discs to be used on 5" pistol grip grinders rated at 20,000 rpm.



An AVOS back-up pad must be used with all AVOS discs.



The quick change Speed-Lok disc goes on with a twist.

AVOS Speed-Lok Grinding Discs and AVOS Speed-Lok Bear-Tex Discs

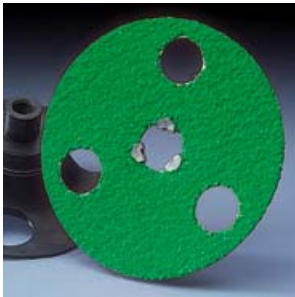

The Edger design will not "catch" on edges. Use on 5" Speed-Lok back-up pad.

Hole design allows for vision and cooler sanding. Actually removes swarf build-up and increases cut rate. Great for faster, cooler sanding. The grinding angle for conventional discs is 45°. AVOS discs allow you to grind at a flatter 5°, resulting in significantly more effective/uniform grinding action.

Norton GreenLyte Plus SG - Ceramic stays sharp longer and is ideal for difficult to grind materials.

NorZon Blue Stripper - Fast cutting zirconia alumina is ideal for rough stock removal.

AVOS Bear-Tex:

Fine: removes 180-320 grit grindlines and is excellent for finishing, polishing, and paint preparation.

Medium: removes 120-180 grit grindlines and is excellent for cleaning and rust removal.

Coarse: removes 60-120 grit grindlines and is excellent for deburring.

SIZE	5" EDGER	PACKAGE	PKG/CASE
------	----------	---------	----------

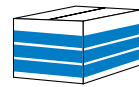

GRIT	662611-		
------	---------	--	--

Norton GreenLyte Plus SG

60	44049	10	4
50	44048	10	4
36	44047	10	4
24	44046	10	4



NorZon Blue Stripper

80	26560	10	4
60	26559	10	4
50	26558	10	4
36	26557	10	4
24	26556	10	4



SIZE	5"	PACKAGE	PKG/CASE
------	----	---------	----------



GRIT	662610-		
------	---------	--	--

Bear-Tex

Fine	09429	10	4
Medium	09428	10	4
Coarse	09427	10	4

AVOS Speed-Lok Back-Up Pads



AVOS back-up pads are designed exclusively for use with patented AVOS fibre discs and AVOS Bear-Tex discs.

Our 5° back-up pad allows flatter sanding and reduced gouging, removing debris from sanding area to reduce loading and improve cut rate.

The special high RPM back-up pads include an adapter which allows the AVOS Speed-Lok system to be used on pistol grip sanders rated for 20,000 RPM or less.

SIZE	5" SPEED-LOK BACK-UP PAD	RPM	CASE
------	--------------------------	-----	------

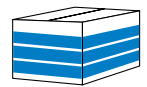

	636425-		
--	---------	--	--

For Pistol Grips

3/8" -24	03029	20000	5
7/16" -20	03030	20000	5

Standard Back-up Pads

3/8" -24	02822	13000	5
5/8" -11	02517	13000	5
M-14 x 2	02823	13000	5

NORTON GREENLYTE SG AND SG

Norton GreenLyte SG and SG... Fastest cutting, longest lasting

Norton GreenLyte SG and SG abrasives provide the fastest cutting and longest lasting abrasive grinding discs. The self-sharpening design is ideal for high pressure, heavy metal removal applications. Perfect for use on weld grinding.

FEATURES

- GreenLyte SG
- Patented Norton SG ceramic aluminum oxide grain

BENEFITS





- Long life, fast cut
- Fast, cool-cutting action
- Extended life

GreenLyte SG Grinding Discs, SG Speed-Lok Discs and Speed-Lok TR Discs





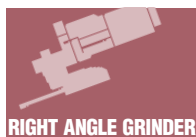

The self-sharpening design of these discs is ideal for high pressure, heavy-metal removal applications such as weld grinding.

Fibre Discs

SIZE	5" X 7/8"	7" X 7/8"	9-1/8" X 7/8"	PACKAGE	PKG/CASE
					
GRIT	662611-	662611-	662611-		
120	41314	41321	-	25	1
100	41315	41322	-	25	1
80	41316	41323	-	25	1
60	41317	41324	41341	25	1
50	41318	41325	41342	25	1
36	41319	41326	41343	25	1
24	41320	41327	-	25	1



Speed-Lok and Speed-Lok TR Discs

SIZE	2"	2" TR	3"	3" TR	PACKAGE	PKG/CASE
						
GRIT	662611-	662611-	662611-	662611-		
120	37776	37752	37780	37755	25	1
80	37775	37751	37779	37754	25	1
60	37774	37750	37778	37753	25	1
50	37773	17913	-	17935	25	1
36	-	37756	-	37757	25	1



The Speed-Lok and Speed-Lok TR discs allow for quick, tool-free disc change, and increased production. They twist-on and twist-off and lock securely to the back-up pad.

**new
improved!**



Medallion.... Stronger by design.

For unmatched premium performance on the job, nothing beats Norton's Medallion Cut-Off Blades. Norton's exclusive combination of high performance abrasives make Medallion Blades the ultimate choice for cool, easy cutting of sheet metal. Also ideal for heavy-duty cutting of muffler clamps, bolts and steel rods up to 3/4" thick, as well as spot weld grinding. Fiberglass reinforced with a special reinforced bond, Medallion Blades are available in three thicknesses, each establishing a new standard in its class.

Medallion blade technology can operate at a higher speed than conventional blades, even in excess of 25,000 RPMs. This ensures much cleaner, faster cuts. More important, it quickly increases productivity on the floor and yields far longer worklife. So, whatever you need to cut, reach for the specific Medallion product for the job.



MEDALLION CUT-OFF BLADES

Medallion Cut-Off Blades



Medallion Cut-Off Blades deliver premium, unmatched performance on the job. Fiberglass reinforced with a special resinoid bond and available in three thicknesses, Medallion Cut-Off Blades are the ultimate choice for cool, easy, free-cutting of sheet metal, or heavy duty cutting of muffler clamps, bolts, and steel rods up to 3/4" thick, as well as spot weld grinding.



		RPM	PACKAGE	PKG/CASE
				
SIZE	076607-			
3" x 1/32" x 1/4"	89033	25465	5	10
3" x 1/32" x 3/8"	89032	25465	5	10
3" x 1/16" x 1/4"	89031	25465	5	10
3" x 1/16" x 3/8"	89030	25465	5	10
3" x 3/16" x 3/8"	89034	25465	5	10

NOTE: DO NOT USE ON TOOL WITHOUT A GUARD.

1/32" Blade

- Thinnest, fastest cutting blade made
- Much cooler cut
- Less distortion allows for tighter fit
- Requires less welding
- Excellent for quarter panels

1/16" Blade

- Best anywhere
- Great for demanding applications
- Cuts bolts, rods and frame rails
- Exceptional, extended worklife

3/16" Blade

- Makes quick work of spot welds
- Thickness improves control when moving blade side to side
- Longest lasting blade available

DEPRESSED CENTER WHEELS



Depressed Center Wheels... Great performance, great value

Norton's depressed center wheels are the industry's most advanced line of performance and value products for weld and flame cut grinding and steel and non-steel metal fabrication applications.



Charger

This blended aluminum oxide and zirconia alumina product is the best choice for the customer who wants a superior product at a value price. Charger wheels offer versatile performance on stainless steel and a wide variety of metals.



Gemini

This aluminum oxide product sets the industry standard for cut rate and performance at very competitive prices.

FEATURES

- Unique blend of premium NorZon (zirconia alumina) and aluminum oxide

BENEFITS



- 2X the life of aluminum oxide wheels
- Effectively grinds a variety of metals from alloys and stainless to gray iron
- Lower total grinding cost

FEATURES

- Advanced formulation
- Gemini Fast Cut wheels
- Gemini 1/16" Thin wheels

BENEFITS

- Free cutting without a reduction in wheel life
- Maximizes the performance of conventional aluminum oxide abrasive
- Engineered to cut hard materials
- Extra thin for quick cutting action
- Special reinforcement design provides safety, strength and straight cuts.

SIZE D X T X H	CHARGER	GEMINI	MAX RPM	CASE
				

1/4" Metal/Steel Grinding - Type 27 Depressed Center Wheels

3" x 3/16" x 3/8"	-	662435-28785	18000	20
3" x 1/4" x 3/8"	-	662435-28855	18000	20
4" x 1/4" x 3/8"	662435-29899	662435-29748	15280	20
4" x 1/4" x 5/8"	662435-29852	662435-30620	15280	20
4-1/2" x 1/4" x 5/8"-11	662528-29855	662528-30432	13580	20
4-1/2" x 1/4" x 7/8"	662528-29856	662528-30611	13580	20
5" x 1/4" x 5/8"-11	662528-29859	-	12225	20
5" x 1/4" x 7/8"	662528-29861	662528-30615	12225	20
7" x 1/4" x 5/8"-11	662529-29864	FC 662529-40147	8600	10
7" x 1/4" x 7/8"	662529-29865	FC 662529-40099	8600	20
9" x 1/4" x 5/8"-11	662530-29868	FC 662530-49105	6600	10

FC = FAST CUT



Cut-off Wheels... Make the Cut

This reinforced cut-off product line provides premium performance in all cut-off applications.

PRODUCT OFFERING:

- Portable grinder small diameter (3" - 4")
- Chop saw (10" - 16")

Small Diameter Reinforced Cut-off Wheels (3" - 4")



Norton cut-off wheels are unequalled in life and cut rate for the highest productivity on a wide variety of metals.



FEATURES

NorZon

- NORZON The Absolute Force

BENEFITS

- Up to 3X life over aluminum oxide wheels on carbon steel and cast iron
- 40% faster cut rate over standard aluminum oxide wheels

Gemini

- Aluminum oxide abrasive

- Good life, cool cut

			RPM	CASE
SIZE D X T X H	NORZON THE ABSOLUTE FORCE 662435-	GEMINI 662435-		
3" x .035" x 3/8"	10669	FC 10628	25465	25
3" x 1/16" x 3/8"	FC 10671	FC 10647	25465	25
4" x .035" x 3/8"	10675	FC 10630	19100	25
4" x 1/16" x 3/8"	FC 10677	FC 10655	19100	25

FC = FREE CUT

Performance Cut-Off Blades



Performance Cut-Off Blades cut 50% faster and last twice as long as conventional blades. Excellent for sheet metal work, cutting clamps and rusted bolts. For use with utility cut-off tool that has similar specifications. Follow all safety precautions.





		RPM	PACKAGE	PKG/CASE
SIZE	076607-			
3" x 1/32" x 3/8"	89018	26570	5	20
3" x 1/16" x 3/8"	89014	26570	5	20

Value Cut-Off Blades



Value Cut-Off Blades are the choice for volume purchases. Effective for cutting autobody sheet metal, hangers, clamps, and rusted bolts.

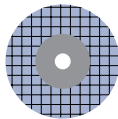

	RPM	PACKAGE	PKG/CASE
			
SIZE	076607-		
3" x 1/32" x 3/8"	89011	21260	100
3" x 1/16" x 3/8"	89012	21260	100

Chop Saw Reinforced Cut-off Wheels (10" - 16")



Offered in type 1 straight Free Cut and Long Life.





Gemini

FEATURES

- Aluminum oxide abrasive
- Side reinforced

BENEFITS

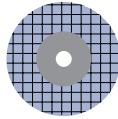
- Consistent cut, good life
- Resist breakage and provide straight cuts

	RPM	CASE
		
SIZE	GEMINI	
10" x 7/64" x 1"	LL 662531-06109	6110
12" x 7/64" x 1"	LL 662532-07554	5095
14" x 7/64" x 1"	RC 662533-13588	4365
16" x 7/64" x 1"	LL 662534-10198	3820

LL = LONG LIFE, RC = RAPID CUT

TechTips

- Use Long Life chop saw wheels on small cross section workpieces.
- Use Rapid Cut chop saw wheels on hard-to-cut materials and on older or low horsepower machines.



BENCH & PEDESTAL WHEELS





BENCH & PEDESTAL WHEELS

Bench & Pedestal Wheels... for the daily grind.

Gemini Bench & Pedestal wheels with heavy duty vitrified bond deliver consistent performance at competitive prices. They are offered in grey aluminum oxide (Alundum) for steel applications.



		RPM	CASE
			
SIZE	ALUMINUM OXIDE		
6" x 3/4" x 1"	Coarse	662528-37103	4140 1
	Medium	662528-37102	4140 1
	Fine	662528-37101	4140 1
6" x 1" x 1"	Coarse	662528-37958	4140 1
	Medium	662528-37957	4140 1
	Fine	662528-37100	4140 1
7" x 1" x 1"	Coarse	662529-42292	3600 1
	Medium	662529-42294	3600 1
	Fine	662529-42295	3600 1
8" x 3/4" x 1"	Coarse	662530-42315	3600 1
	Medium	662530-42316	3600 1
	Fine	662530-42317	3600 1
8" x 1" x 1"	Coarse	662530-44449	3600 1
	Medium	662530-44448	3600 1
	Fine	662530-44447	3600 1
10" x 1" x 1-1/4"	Coarse	662531-60787	2485 1
	Medium	662531-60789	2485 1
	Fine	662531-60350	2485 1

Bench & Pedestal Wheel Arbor Bushings

WHEEL DIA	WHEEL CENTER HOLE	1/2"	5/8"	3/4"	7/8"	1"
6"	1"	■	■	■	■	
7"	1"	■	■	■	■	
8"	1"		■	■	■	
10"	1-1/4"			■	■	■

■ THESE SIZE BUSHINGS SHIPPED FREE OF CHARGE WITH YOUR WHEEL ORDER

Cartridge Rolls



Designed for grinding, deburring, blending, finishing or polishing a wide variety of materials.



DIE GRINDER

Straight Cartridge Rolls (Pencils)

DIAMETER X LENGTH X CENTER HOLE	METALITE R228	PACKAGE	PKG/CASE
---------------------------------	---------------	---------	----------



SIZE	GRIT	636425-	PACKAGE	PKG/CASE
3/8" x 1-1/2" x 1/8"	60	42012	50	10
	80	42008	50	10
	120	42000	50	10
1/2" x 1" x 1/8"	60	42033	50	10
	80	42029	50	10
	120	42021	50	10
1/2" x 1-1/2" x 1/8"	60	42053	50	10
	80	42049	50	10
	120	42041	50	10

Tapered Cartridge Rolls (Spirapoints)

BASE DIAMETER X OVERALL HEIGHT X CENTER HOLE	METALITE R228	PACKAGE	PKG/CASE
--	---------------	---------	----------



SIZE	GRIT	636425-	PACKAGE	PKG/CASE
3/8" x 1" x 1/8"	60	42289	50	10
	80	42286	50	10
	120	42280	50	10
1/2" x 1-1/2" x 1/8"	60	42319	50	10
	80	42316	50	10
	120	42310	50	10

Threaded Mandrels

These precision machined, high grade steel mandrels are designed for use with abrasive pencils and spirapoints. Select a shank diameter to fit the chuck or collet of your power tool.

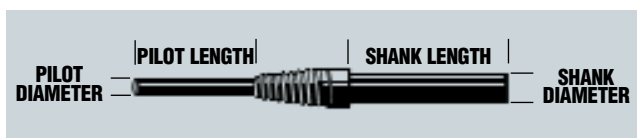

PILOT DIAMETER	PILOT LENGTH	SHANK DIAMETER	SHANK LENGTH	CASE
----------------	--------------	----------------	--------------	------



636425-				
1/8"	3/4"	1/4"	1-1/4"	43066 10
1/8"	1"	1/4"	1-1/4"	43068 10

SpecCheck

IF PENCIL OR SPIRAPOINT DIAMETER IS 1/2" or less PILOT DIAMETER SHOULD BE 1/8"

IF PENCIL OR SPIRAPOINT LENGTH IS 1" PILOT LENGTH SHOULD BE 3/4"
 1-1/2" PILOT LENGTH SHOULD BE 1"

TAPES AND MASKING PRODUCTS

MASKING TAPE / FINE LINE TAPE







Tapes and Masking Products... Designed specifically for the professional auto refinisher.

From drawing board to body shop, all Norton tapes and masking products are tested and re-tested to establish new standards of performance that will save body shop pros time and money without sacrificing the highest degree of excellence.

Masking Tape

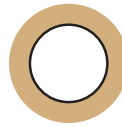





SIZE	18MM (3/4")	36MM (1-1/2")	48MM (2")	CASE
				
DESCRIPTION	636425-02492	636425-	636425-	
55m Roll	02492	-	-	48
55m Roll	-	72112	72200	24

Norton Masking Tape goes on easy, sticks fast and holds tight. It conforms easily to contours and irregular surfaces and is resistant to temperatures up to 260°F for up to 1 hour. It exhibits no bleed-through, seepage or flaking and leaves no residue when removed.

Fine Line Tape



SIZE	1/8"	1/4"	1/2"	CASE
				
DESCRIPTION	636425-72018	636425-72014	636425-72012	
36 Yard Roll	72018	72014	72012	12

Fine Line Tape conforms easily to contours and irregular surfaces. It adheres to a variety of surfaces. This tape's unique thinness allows for minimum edge build-up and leaves no residue when removed. It performs on bake cycles up to 180°F.

Cloth Duct Tape

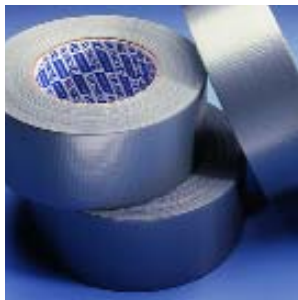

An industrial quality silver polyester cloth tape providing excellent adhesion to a wide variety of surfaces. Highly conformable and moisture resistant, Norton Cloth Duct Tape is ideal for sealing, patching, reinforcing, and other general purpose repair applications.

SIZE	2" X 60 YARDS	CASE
DESCRIPTION	636425- Cloth Duct Tape - Silver	78000 24

Premium Automotive Attachment Tape



SIZE	1/4" X 20 YDS	1/2" X 20 YDS	7/8" X 20 YDS.	CASE
DESCRIPTION	636425- Attachment Tape .045" Thick	05620	636425- 05621	636425- 05622
				12

High-density gray foam tape coated with high strength acrylic adhesive on both sides with red Mylar release liner is designed for bonding medium to large moldings and accessories. High strength acrylic adhesive provides superior adhesion to plastics, metal, and glass and painted vehicle surfaces.

- Used for attaching body side moldings, cladding, door edges, emblems, fascia rub strips, garnish moldings, interior trim panels, rocker panel moldings and pillar covers
- Instant pressure sensitive bonding
- Remains flexible at low temperatures
- Will not absorb moisture
- Conforms to irregular surfaces

Attachment Tape Adhesion Promoter



Molding Tape Adhesion Promoter is a liquid primer to improve the adhesion of acrylic foam attachment tape to exterior and interior trims involving injection molded and/or plastics (TPO, PPO, PP, PG, PC and ABS).

SIZE	220 ML. CAN	CASE
DESCRIPTION	636425- Molding Tape Adhesion Promoter 220ml brush top can	05623 12

Automotive Attachment Tape

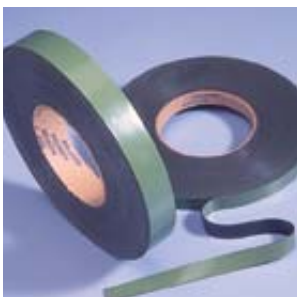

Quality Automotive Attachment Tape is ideal for mounting side moldings, emblems, trim parts, and other double-coated tape applications. Width sizes fit popular applications while the black color of the tape hides well from detection. Constructed with advanced adhesive system on a closed-oil urethane foam.

SIZE	1/2" X 20 YDS	7/8" X 20 YDS.	CASE
DESCRIPTION	636425- Attachment Tape	636425- 76377	76378 12

TAPES AND MASKING PRODUCTS

Automotive Polycoated Masking Paper



SIZE	6"	12"	18"	24"	36"	CASE
DESC.	076607-	076607-	076607-	076607-	076607-	
500' (boxed)	00829	00830	00831	-	00832	1
DESC.	636425-	636425-	636425-	636425-	636425-	
1000' (taped)*	-	77012	77018	77024	77036	1

***APPROXIMATE SIZES**

Norton Masking Polycoated Paper is the choice of automotive painters for providing protective aprons over adjoining areas during repaint operations. Protects against penetration or over-spray. Norton Masking Polycoated Paper is strong, flexible and pliable.

NorMag Foam Aperture Masking Tape



Norton NorMag is a semi-closed cell foam with a double-sided non-woven adhesive surface with a release liner to prevent contamination. The foam is highly compressible and returns easily to its initial shape. NorMag is durable and adheres perfectly under all temperatures. NorMag fits perfectly into straight and curved areas for all vehicles and can be re-positioned several times.

SIZE	30M ROLL	CASE
DESCRIPTION	636425	
NorMag Foam Masking Tape	05665	4

NorMag's convenient 30 meter (32.8yard) single length roll cardboard spool box is simple to handle and easy to store. Cut exactly the length you need each and every time, avoiding unnecessary waste. The NorMag dispenser box is dust-proof and includes all instructions for use.

- One convenient size, continuous roll with release liner to prevent contamination. Leaves no trace of adhesive after removal. Easy and quick to apply.
- Easily torn by hand. No cutting tool required.
- Can be re-positioned several times.
- Extremely flexible and can be used on 90° bends. Can be butt-joined easily, in a straight line or a curve. Makes it easy to mask straight lines, curves on edges or recessed panels, doors, and fenders.
- Ensures seal between bodywork and opening components with a gap of 1/8" to 1-1/4". Protects against paint over spray.

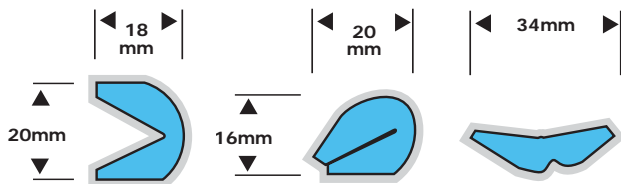

18 MM (3/4") X 20 MM (7/8") ORIGINAL SHAPE
34 MM (1-3/8") WHEN OPENED TO MAXIMUM WIDTH.

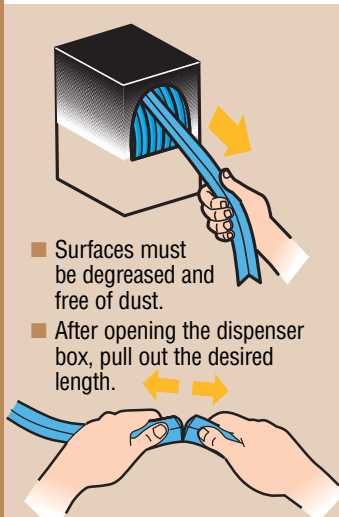

- Surfaces must be degreased and free of dust.
- After opening the dispenser box, pull out the desired length.

- Break off required length of foam tape by hand - no cutting tool required

- Remove protective release liner

- Apply by pushing down on one end with thumb
- Keep fingers underneath the lip of the seal in order to exert pressure more effectively

- Keep the rounded edge facing out
- For wider gaps: keep rounded edge facing in and extend to 34mm (1-3/8")
- Use as many pieces as needed
- On body panel joints, it is advisable to remove NORMAG foam masking tape after baking
- NORMAG is suitable for use with any solvent - or water-based paint system

- NORMAG foam masking tape can be removed: on removal from baking oven *or* once paintwork is dust free *or* after the vehicle has cooled (no risk of adhesive residue)



Blue Sheeting



FEATURES

- Tri-layer paintable sheeting
- Corona treated
- 3-ply resin formula
- Plastic
- Wide widths
- Self-dispensing perforated box

BENEFITS

- Clings
- Easy to handle - fast application
- Clings after repositioning
- Paint won't flake off – eliminates use of paper
- Holds paint like paper
- Resists tearing
- Resistant to solvents
- No bleed-through
- One pass coverage
- Fast application increases productivity
- Easy for one person to dispense
- Protects sheeting from dust and dirt

With Norton Blue Sheeting, paint will adhere to the outside layer of plastic, eliminating paint flake-off, allowing for direct spray. Blue Sheeting features an easy-to-open fold pattern. All sizes come on a standard core to fit all current plastic masking dispensers, so one person can mask the vehicle alone. The cling of Blue Sheeting ensures the material adheres to the area that is to be protected. Blue Sheeting can be cut and painted along the critical edge, replacing paper in the shops. This tri-layer plastic is .04 mil thick.

SIZE	12' X 400'	14' X 350'	16' X 350'	20' X 350'	CASE
DESCRIPTION	636425-03344	636425-03697	636425-03345	636425-03723	1
Blue Sheeting					

Application Steps



Step 1

Lay down a tape line along the critical edge. We recommend Norton Masking Tape. Be sure the entire vehicle is dry. Blue Sheeting is not to be used on a wet surface.

Step 2

Cover the vehicle completely with Blue Sheeting. "Spray This Side" is clearly marked in English and Spanish to indicate the correct paintable surface. The Blue Sheeting will CLING to the vehicle and hold in place. Blue Sheeting can be repositioned and it will maintain its cling. One person can cover the vehicle in less than 2 minutes.

Step 3

Use a safety razor to cut away the excess material. Cut right along the tape line. If working along a door or hood, the excess material can be folded in the door or laid over the motor for extra protection. There is no need to use paper next to the critical edge. Blue Sheeting will cling solidly to the vehicle and will not flake paint, even when hit with a blast of air.

Step 4

Tape the Blue Sheeting in place to the tape line laid down in step 1. The vehicle is ready to paint. You don't have to waste time masking the critical edge with paper. Blue Sheeting does it all for you: clings to the vehicle, does not flake off paint and protects the entire vehicle from overspray. All in one easy to use product.

Blue Wrap Protective Plastic

new!



CASE



DESCRIPTION	636425-	
Self Adhesive Weather Barrier 36" x 100' (9 lbs.) 3 mil thick	05920	1
Seat Covers (125/roll) Non-Slip	05921	1
Wheel Maskers (50/roll) Paintable	05922	1
Floor Mats (125/roll) Non-Slip	05923	1



Blue Wrap Self Adhesive Weather Barrier

Blue Wrap weather barrier is guaranteed not to leave any adhesive residue for up to 30-days when used according to recommended procedures:

- Do not leave Blue Wrap in place for more than 30 days
- Do not expose Blue Wrap to extreme temperatures above 170° F
- Do not install on wet or damp surfaces
- Reverse wound roll for easy application by one person
- 36" width allows for one pass coverage on most cars, SUV's and light trucks
- Clear film with built in UV inhibitors for interior protection

Designed as a temporary weather barrier for a broken window, windshield, sunroof, sprung door or missing panel, Blue Wrap keeps the interiors of damaged vehicles dry and clean when stored outside. Blue Wrap weather barrier adheres well to metal and to glass yet can be easily repositioned.

Blue Wrap Wheel Maskers

- Tri-layer plastic
- Paintable - NO Flaking
- Fully covers both sides of the wheel
- Covers tires up to 17"

Blue Wrap wheel maskers have excellent cling, superior paint adhesion and are easy to dispense from a perforated roll. Unlike competitive "shower cap" and hooded maskers that only protect the outside of the tire, Blue Wrap wheel maskers cover both sides of the wheel to ensure that tires and wheels remain paint free.

As an added feature, greasy spare parts that are typically stored inside on the rear seat or floor can be placed inside a wheel masker and tossed in the rear seat area eliminating the need for added cleanup.

Blue Wrap Seat Covers

- Full coverage from headrest to floor
- Will not slip or bunch up
- Protects seats from grease, dust and chemicals
- Dispenses easily from perforated roll

The Blue Wrap seat cover is a unique two-layer, co-extruded patented product that protects vehicle seating surfaces from grease, oil and most chemicals. The co-extrusion process allows the bottom layer to grip the seat and hold the seat cover in place while the top layer provides access for technicians to slide in and out with ease.

Blue Wrap Floor Mats

- Impervious to water, grease and chemicals
- Will not slip or tear
- Protects floor from dirt, grease and chemicals
- Dispenses easily from perforated roll
- Generous size: 16-1/2" x 21"

The Blue Wrap floor mat, like the seat cover, is a unique two-layer, co-extruded product that protects vehicle seating surfaces from grease, oil and most chemicals. The co-extrusion process allows the bottom layer to grip the floor and hold the protective mat in place. It's also a nice "thank you" your customers can see when they pick up their car.



Norton accessories... For superior performance.

For superior sanding performance, Norton sanding accessories are made of top quality construction. Sets of these products will enhance and improve Norton product performance.

Norton Automotive Refinishing Utility Cabinet



Automotive Utility Cabinet features rugged, heavy gauge steel to protect your materials. It has two adjustable shelves and security latches for locking all doors. You can store all of your abrasives, tapes and chemicals, while keeping them clean, dry and secure. The sidewalls are pre-punched to mount 6 Norton disc roll/sheet roll dispensers.

SIZE	32"W X 13"D X 26"H	CASE
		
DESCRIPTION	636425-	
Automotive Utility Cabinet	42770	1



The Adhesives & Sealers Cabinet is heavy gauge steel and will hold all of the Norton Adhesive and Sealers keeping them dry, clean and secure.

SIZE	15"W X 13"D X 30"H	CASE
		
DESCRIPTION	636425-	
Adhesives & Sealers Cabinet	02532	1



Norton Bucket



Pre-soak waterproof paper in this sturdy blue bucket or use it with NorWash mitts to wash cars before customer delivery.

		CASE
		
DESCRIPTION	636425-	
Bucket	04413	5



Rubber Slush Wiper

For removing slush created when wet sanding primers, primer surfaces and paints. Also ideal for applying putty and body filler. Made of flexible rubber.

SIZE	3" X 2" X 3/16"	CASE
		
DESCRIPTION	636425-	
Rubber Slush Wiper	43115	50

Rubber Hand Sanding Block



Ideal for uniform sanding. Can be used for dry or wet sanding. Uses a 2-3/4" x 9" sheet which is 1/4 of a standard 9" x 11" sheet. Slotted jaws securely hold sheets in place. Rubber composite adjusts well to surfaces.

		CASE
		
DESCRIPTION	076607-	
Rubber Hand Sanding Block	43140	14

Ergonomic Hand Sanding Block for 6" Discs





The unique design quickly converts a 6" diameter PSA or Speed-Grip disc into a hand sander. The ergonomic design of the pad fits the user's fingers for added comfort and reduced fatigue.

		CASE
		
DESCRIPTION	636425-	
For 6" PSA Discs	03727	5
For 6" Speed-Grip Discs	03726	5

Dual Density Wet Sanding Block

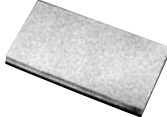

Because of the "grabbing" power of these blocks, no adhesive is required, simply wrap the paper around the block. The dense side is for more aggressive blocking, while the soft side is for color sanding. These blocks come in a "point of purchase" display pack.

		CASE
		
DESCRIPTION	636425-	
Wet Sanding Block	03728	12

Holey Block

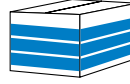

A rugged, semi-rigid, multi-purpose sanding block engineered for flat to medium curved surfaces. A tactical hole pattern side provides numerous cutting edges to create a 30% faster cut rate. The plain side provides firmness and a comfortable, easy-to-hold surface. These blocks come in a "point of purchase" display pack.

		CASE
		
DESCRIPTION	636425-	
Holey Block	03729	8

Blue Magnet Micro-Fiber Wipe



Picks up dirt like a magnet with thousands of advanced micro-fabric fibers. Can hold 7 times its weight in water. Perfect for fine detailing.

SIZE	16" X 16"	PKG	PKG/CASE
			
DESCRIPTION	636425-		
Micro-Fiber Cloth	04402	5	4

Norton Automotive Disc Roll and Sheet Roll Dispensers

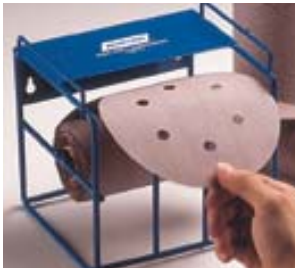



Norton Automotive Disc and Sheet Roll Dispensers feature heavy duty construction and a rubberized finish, designed to protect your product, as well as the finish on your workpiece. Norton dispensers are versatile, for use with any 5" or 6" disc roll or sheet roll. They can

		CASE	
			
DESCRIPTION	636425-		
Double Disc Roll Dispenser	02981	1	
Single Disc Roll Dispenser	42772	1	
Sheet Roll Dispenser	42773	1	

be attached to a wall, mounted on a Norton Utility Cabinet, or stacked upon other Norton dispensers. Keeps rolls neat and at your fingertips.

Norton Tack Cloths

The Norton Tack Cloth is a soft cloth impregnated with a special formula that effectively removes dust, dirt and sanding residue. It contains no waxes or silicones, and is compatible with all paints and lacquers, even polyurethane and epoxy paints. This cloth is always soft and tacky, and will never dry out. It is also spontaneous combustion proof, non-toxic and anti-static. This top quality tack cloth features a 20 x 16 square mesh. It's folded to 4-1/2" x 4-1/2" and sealed in an easy-open polybag for protection and storage.

SIZE	18" X 36"	PACKAGE	PKG/CASE
			
DESCRIPTION	076607-		
Tack Cloth	49008	12	12

SoftTouch Sponges



The finishing action of sponges generates a finer finish than when using conventional coated products.

GRIT DESIGNATION	FINISH GENERATED
Medium	P180/P120
Fine	P400/P320
Super Fine	P600/P500
Ultra Fine	P1000/P800
Micro Fine	P1500/P1200

Benefits of SoftTouch sponges:

- Can be used wet or dry
- Fits comfortably in your hand
- Flexible design for multiple applications
- Uniform finish

SIZE	4-1/2 X 5-1/2 X 3/16	PACKAGE	PKG/CASE
			
DESCRIPTION	076607-		
Medium	03074	20	4
Fine	03075	20	4
Super Fine	03076	20	4
Ultra Fine	03077	20	4
Micro Fine	03078	20	4

Applications:

- Medium - scuff, shaping filler
- Fine - feather-edge, scuffing primer, scuffing new parts before painting
- Super Fine - preparing panel for base coat
- Ultra Fine - sanding base coat, denibbing clear coat defects
- Micro Fine - clear coat sanding, denibbing minor defects

Belt Pulley Reconditioner



This product is used on both serpentine and v-belts to stop belts from squealing. Also deglazes belt. This product is great for walk-in trade in a pegable retail package.

		PKG.	PKG/CASE
			
DESCRIPTION	076607-		
Belt Pulley Reconditioner	04777	10	10

Low Profile Back-Up Pads for Dual Action/Random Orbital Sanders

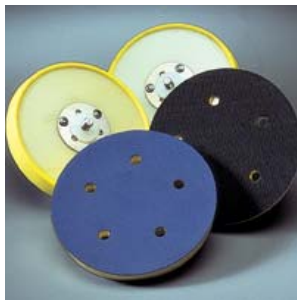

The low profile design (1/2" thick) is specifically balanced to eliminate vibration to enhance fine grit sanding. Designed with medium density polyurethane foam for conformability, these pads are firm enough for flat surfaces, yet soft enough for severe curves and contours. The vacuum is available in standard 5-hole pattern or a 6-hole pattern. The backing plate is fiberglass with a riveted 5/16" -24 threaded shank.

PSA

SIZE	PSA	PSA VAC	RPM	CASE
	636425-	636425-		
5" Low Profile	03112	03113	10000	5
6" Low Profile	05581	05583	10000	5

Speed-Grip

SIZE	SPEED-GRIP	SPEED-GRIP VAC	RPM	CASE
	636425-	636425-		
5" Low Profile	03119	03120	10000	5
6" Low Profile	05582	05584	10000	5

Speed-Grip Disc Back-Up Pads



Designed exclusively for use with Speed-Grip discs, the pad face has numerous hooks designed to securely lock the disc to the pad, permitting easy application and removal.

5" and 6" diameter pads have 5/16"-24 threaded shank; the 8" diameter pad has a 5/8"-11 threaded female hub. All pads have a tapered edge.

Plain





SIZE	5"	6"	8" X 5/8-11"	RPM	CASE
DESCRIPTION	636425-	636425-	636425-		
Speed-Grip	-	43856	-	10000	5
Back-Up Pads	-	-	43704	3200	5
Value Back-Up Pads	84502	84602	-	10000	1

Vacuum

SIZE	6"	8" - 5 SCREW	8" - 6 SCREW	RPM	CASE
DESCRIPTION	636425-	636425-	636425-		
Speed-Grip Vacuum	43857	-	-	10000	5
Back-Up Pads	-	43712	43714	3200	1

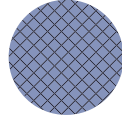
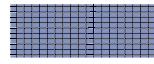

PSA Conversion Discs and Strips

Permanent adhesive on textile hook backing allows for easy conversion of Stick and Sand Pads to Speed-Grip.

SIZE	5"	6"	8"	2-3/4" X 16"	CASE
					
DESCRIPTION	636425-02469	636425-02470	636425-02471	636425-	CASE
Disc	02469	02470	02471	-	20
Strip	-	-	-	02472	20

Soft Foam Interface Pads





Designed for use with our fine grit Speed-Grip dry sanding discs. Improves both surface finish and cut rate. Use with Speed-Grip Disc Back-Up Pads.

SIZE	5" FOAM	6" FOAM	PACKAGE	PKG/CASE
				
DESCRIPTION	636425-02161	636425-02162	2	10
Interface Pads	02161	02162	2	10

Speed-Lok Disc Back-Up Pads



Designed for use with Speed-Lok cloth and fibre discs. Each disc has a built-in center hub that enables Speed-Lok discs to be mounted, locked in place, and removed quickly and easily with a simple twist of the wrist. Constructed of molded rubber, Speed-Lok Disc Pads provide firm support to improve disc performance and abrasive life.

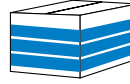

SIZE	2"	3"	5"	7"	RPM	CASE
						
DESCRIPTION	636425-	636425-	636425-	636425-		
Speed-Lok	-	-	-	-	40000	10
Back-Up	43210	-	-	-	25000	10
Pads	-	43225	-	-	20000	10
	-	-	43235	-	12000	5
	-	-	-	43245	8600	5

2" - 3" PADS HAVE A 1/4" SHANK. 5" - 7" PADS HAVE A 5/8-11 THREADED FEMALE HUB.

Speed-Lok TR Disc Back-Up Pads





Speed-Lok TR Disc Back-Up Pads are for use with Speed-Lok TR Discs. Easily mounted and locked in place, these durably constructed back-up pads are expressly designed to fit all Norton TR discs as well as Roloc™ discs from other manufacturers.

SIZE	2"	3"	RPM	CASE
				
DESCRIPTION	662610-	662610-		
Speed-Lok TR	55103	-	25000	10
Back-Up Pads	-	55105	20000	10

Bear-Tex Speed-Grip Disc Back-Up Pads



Gripper-faced back-up pads provide easy, "press-on" mounting to firmly anchor Bear-Tex Surface Blending Discs.





SIZE	4"	7"	RPM	CASE
				
DESCR.	662610-59356	662610-59368		
Bear-Tex Back-Up Pads	59356	59368	18000 6000	5 5

4" PADS HAVE A 1/4" SHANK.

7" PADS HAVE 5/8-11 FEMALE THREAD.

Glue-On Disc Back-Up Pads



For paper or cloth discs, Glue-On Disc Back-Up Pads have a specially designed fabric inlaid into the pad surface that permits even distribution of manually applied disc adhesive (refer to Disc Adhesive, page 41). 8" pads utilize a high-loft (thick) molded polyurethane foam, formulated to provide a consistent, uniform degree of density and conformability.



SIZE	6"	8" SOFT	8" MEDIUM	RPM	CASE
					
DESCRIPTION	636425-43401	636425-43165	636425-43166		
Glue-On Back-Up Pads	43401	43165	43166	10000 3800	10 5

Stick and Sand Disc Back-Up Pads



Designed for use with all PSA (pressure sensitive adhesive) backed discs. Made of epoxy-glass and molded rubber, the 6" pads (3/4" thick) have a 5/16"-24 threaded shank for use on random orbital or dual action sanders. The 8" pad has a 5/8"-11 threaded female hub. Pads have a tapered edge and the embossed diamond pattern of the vinyl surface provides excellent disc adhesion, while permitting fast, clean and easy removal of used discs without tearing.

SIZE	6"	8"	RPM	CASE
				
DESCRIPTION	636425-43852	636425-43112		
Stick and Sand Back-Up Pads	43852	43112	10000 6000	5 5
Value Back-Up Pads	84600		10000	1

SIZE	6" VAC	8" VAC - 6 SCREW	RPM	CASE
				
DESCRIPTION	636425-43853	636425-43728		
Stick and Sand Vacuum Back-Up Pads	43853	43728	10000 6000	5 1

Air-Cooled Back-Up Pads



For fibre discs and Bear-Tex abrasive brushes, these pads are designed for medium to heavy grinding applications. Slotted aluminum hub plus curved ribs on rubber face of pad promote a cooler cutting action to reduce loading and increase abrasive life by up to 20%. Fits 5/8-11 arbor. Choose medium density for all-purpose grinding; hard density for a more aggressive cut. Select retainer nut for pad of your choice.

SIZE	5"	7"	9"	RPM	CASE
					

DESCRIPTION	636425-	636425-	636425-	RPM	CASE
Med. No Nose	03000	-	-	10000	5
Medium	43421	-	-	10000	5
Medium	-	43422	-	7000	5
Medium	-	-	43423	6600	5
Firm	-	43425	-	8600	5

DESCRIPTION	636425-	CASE
		

DESCRIPTION	636425-	CASE
#103 Retainer Nut for 5" Pad	43463	10
#834 Retainer Nut Spanner Wrench	43005	5